

Model: EIPC-N2800-17T
17" Marine Suitable Intel Atom N2800 Fanless Panel PC with Touch Screen - 5 x COM; IP65 front protection; Optional - WIFI

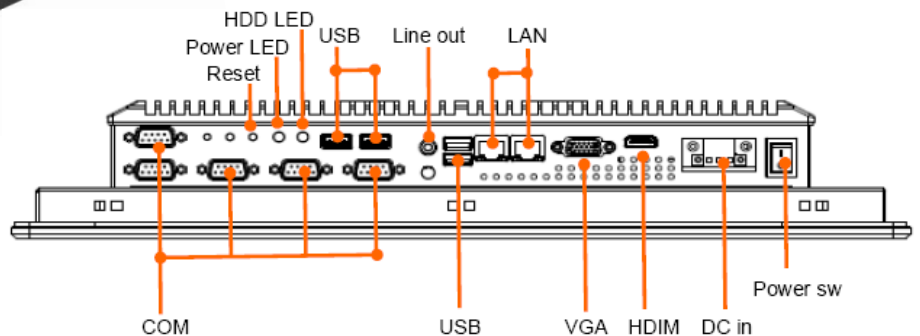

Main Feature

- LED Panel - Higher Brightness; Longer Life Span; Better Viewing Angle; Less Power Consumption ...
- 17" SXGA LED Panel support 1280x1024 pixels
- Intel Atom N2800 (1.86GHz, Dual Core, 1MB Cache, 6.5watt) Processor
- Fanless rugged construction design
- Front 6mm Aluminum bezel - NEMA4 / IP 65 compliant
- 5 x COM (COM2 could set to RS422/485, default on RS232)
- Wide Range 9-28VDC input
- (Optional - Touch Screen) Front hardness glass protect screen
- (Optional - WIFI) MINI PCI-E WIFI Module with Antenna
- Panel (Flush) mounting with clip
- Meet standard VESA hole (75 & 100 mm), support desk top stand / wall mount / swing arm mounting

Specification	
Product Model	EIPC-N2800-17T
CPU	Intel Atom N2800 (1.86GHz, Dual Core, 1MB Cache, 6.5watt)
Chipset	Intel HM10
Memory	1 x DDRIII SO-DIMM RAM Socket up to 4GB

Storage	Space for 1 x 2.5" Drive Bay
Display	Display Type : 17" SXGA <u>LED Panel</u> LCD Resolution : 1280 x 1024 Luminance : 300 cd/m ² View Angel : 160° (H), 160° (V)
Audio	Realtek ® ALC662, 6 channel surround audio
LAN	2 x Realtek ® RL8111E (Gigabit) 10/100/1000Ethernet
USB port	4 x USB 2.0
Display output	1 x VGA and 1 x HDMI
Expansive interface	1 x Mini PCI-E
Back panel I/O port	2 x RJ45; 4 x USB 2.0; 1 x VGA ; 1 x HDMI; 1 x Lin-in / Lin-out; 5 x COM; 1 x HDD/PWR LED; 1 x Power / Reset Switch; 1 x PWR-In 3 PIN Terminal Block
Supporting OS	DOS; Windows 2K/XP/Vista/7; Linux
Touch Screen (optional)	Internal USB interface controller - Resistive Touch Internal USB or RS-232 interface controller Type: Analog resistive type : 25VDC ≥ 20MΩ Resolution: continuous Light transmission: 80% or more Power consumption:<5V @1mA Surface hardness : 3H Operating force : ≤100g Life expectancy : 35 Million
Wireless LAN (optional)	MINI PCI-E WIFI Module with Antenna
Power Supply	9-28VDC input with 3 pin termination block
Construction	Heavy duty steel and aluminum front panel
Environment	Operating temperature: -5°C to 60°C Relative humidity: 10% to 90%non-condensing Vibration: 17 to 500HZ 1G PTP; Shock: 1G /peak(11m sec)
Compliance	CE; FCC; ROHS
Dimension W x H x D (mm)	433 x 345 x 71
Ordering Information:	
EIPC-N2800-17T	17" Marine Suitable Intel Atom N2800 Fanless Panel PC with Touch Screen, with 100-240VAC to DC 12V 60W adapter
<u>Optional</u> - RAM	2 to 4GB DDRIII SO-DIMM RAM
<u>Optional</u> - SSD / HDD	16 GB to 1TB SSD / 320GB to 1TB 2.5" SATA HDD
<u>Optional</u> - WIFI	MINI PCI-E WIFI Module with Antenna
<u>Optional</u> - OS	Windows XP or 7 Professional

Structure Diagram

