

Model: SLPM-12
12.1" Slim Line - Industrial Panel Monitor



Main Feature

- 12.1" XGA LED panel support 1024x768 pixels
- 6mm Aluminum Magnesium Alloy front bezel (with PET protection film) - light weight design
- NEMA4 / IP 65 compliant front panel, with Rugged construction design
- Aesthetic ultra-thin front bezel for minimize stain water & dust
- Input signal : VGA + DVI + USB or RS232 (Optional for Touch Screen - 5 wire resistive)
- OSD control keys to optimize the display (Hot-Key for quick "Brightness & Contrast" adjustment)
- Wide Range 12-24VDC Input
- Meet standard VESA hole (75x75 & 100X100mm), support desktop stand/wall mount /swing arm mounting
- Wide Range Operating Temperature -20 °C to 60 °C 

Specification	
Product Model	SLPM-12
LCD Panel	Display Type : 12.1" XGA LED Panel Resolution : 1024x768 Max. color : 16.2M Luminance : 450 cd/m2 View Angel : 130° (H), 120° (V) Pixel Pitch : 0.24 x 0.24 mm Contrast Ratio : 500 : 1 Response Time : 16 ms LED backlight lifecycle : 50,000hrs
Signal Input	VGA + DVI
Protect Glass	3 mm strengthen glass
OSD	Auto; Menu; Left; Right; Exit/Select; Power On/Off (Hot-Key for quick "Brightness & Contrast" adjustment)
Power Supply	Input: 12-24VDC Wide range
Construction	Aluminum magnesium alloy front panel with heavy-duty steel chassis

Environment	Operating temperature: -20 °C to 60 °C Storage temperature: -20 °C to 70 °C Storage humidity: 10% to 95%, non-condensing Vibration: 50 to 500HZ 1G PTP Shock: 10G /peak(11m sec)
Safety	CE/FCC/Rohs
Dimension W x H x D (mm)	Dimensions: 322 x 244 x 49 mm

Ordering Information

SLPM-12	12.1" Slim Line - Industrial Panel Monitor
(Optional) AC to DC Adapter	12VDC/60watt Power Adapter, input 110-240VAC

Structure Diagram (Mounting Hole Size: 305 x 321 mm)

Unit: mm

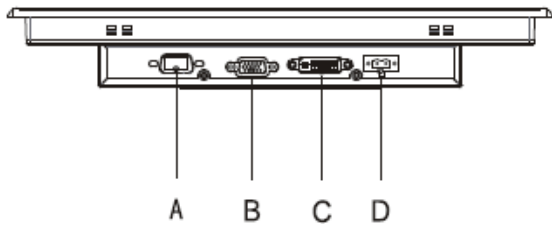
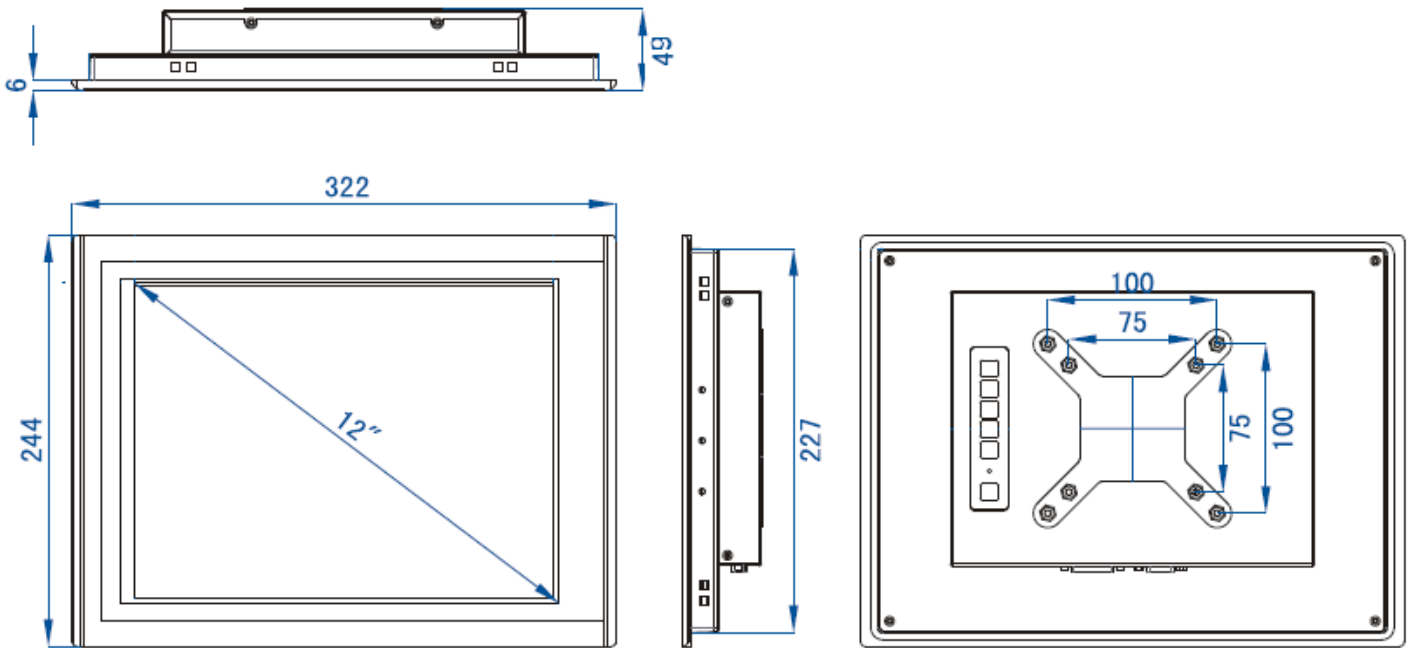

- A: USB or RS232 (for Touch Screen)
- B: VGA input
- C: DVI input
- D: 12VDC (or 9-28VDC) input