

Model: SPC-1519T
15" All Around IP66 Stainless Steel, Touch Panel Computer



Cables included 2 meters length each

Main Feature

- LED Panel - Higher Brightness; Longer Life Span; Better Viewing Angle; Less Power Consumption ...
- Intel® Celeron™ J1900 (Optional upgrade to i3 - 8145U)
- Rugged Fanless Stainless Steel Cooling design
- Anti-scratch touch surface
- All around IP66 with waterproof M12 connectors
- 4GB RAM & 64GB SSD onboard (optional for upgrade to 8GB RAM & 256GB SSD...)
- Industrial 5 wire Resistive touch screen, optional for PCT Touch
- 2 x RS232/485, 2 x GLAN, 2 x USB 2.0
- Support 2 x Mini-PCIe Expansion Slot
- 12 to 24VDC wide range input

Application:

- Factory Automation, Food Processing Factory, Medical Equipment, Marine / Offshore Industrial, Kiosk ...

Specification	
Product Model	SPC-1519T
CPU	Intel® Celeron™ J1900 (2.0GHz, Quad Core, 2MB Cache, up to 2.41 GHz w/ burst frequency enabled)
Chipset	Intel® SOC integrated
Memory	1 x DDR3L SO-DIMM Socket up to 8GB
Storage	1 x mSATA (for SSD)
Display	Display Type : 15" XGA <u>LED Panel</u> LCD Resolution : 1024 x 768 Luminance : 400 cd/m2 View Angel : 160° (H), 160° (V)
LAN	2 x Intel® i210 GLAN

USB port	2 x USB 2.0
COM port	2 x RS232/485 (Pre-set at factory, choose either one at ordering, default on RS232)
Expansive interface	2 x Mini PCI-E (support WIFI, Bluetooth & 3G card)
I/O port	2 x RJ45; 2 x USB 2.0; 2 x COM; 1 x 12-24VDC input ; 1 x Power / Reset Switch
Supporting OS	DOS; Windows 7/8.1/10; Linux
Touch Screen	Internal USB or RS-232 industrial grade 5 wire Resistive Touch controller Resolution: 4096 x 4096 Light transmission: 80% or more Surface hardness : 3H Operating force : ≤100g Life expectancy : 35 Million Operation system : Windows XP / 7 /8.1 / 10 / CE, DOS , Linux
Wireless LAN (optional)	MINI PCI-E WIFI Module with Antenna
Power Supply	AC 100-240V wide range external AC adapter 12V/5A
Construction	All Around Stainless Steel
Environment	Operating temperature: -10°C to 60°C Relative humidity: 10% to 95%non-condensing Vibration: 17 to 500HZ 1G PTP; Shock: 1G /peak(11m sec)
Compliance	CE; FCC; ROHS
Dimension W x H x D	360 x 284 x 54 mm

Ordering Information

SPC-1519T	15'' All Around IP66 Stainless Steel, Touch Panel Computer, with Intel® Celeron™ J1900, 4GB RAM, 64GB SSD, 100-240VAC to DC 12V 60W power adapter
<u>Optional - RAM</u>	Upgrade to 8GB RAM
<u>Optional - SSD</u>	Upgrade to 256GB, 512 GB, 1TB SSD
<u>Optional - WIFI</u>	MINI PCI-E WIFI Module with Antenna
<u>Optional - OS</u>	Windows 7/8.1/10 Professional
<u>Optional - PCT Touch</u>	Upgrade to Projected Capacitive Multi Touch (10 points)

Structure Diagram

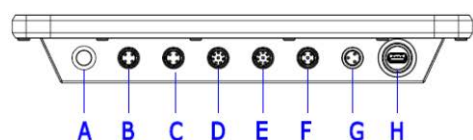
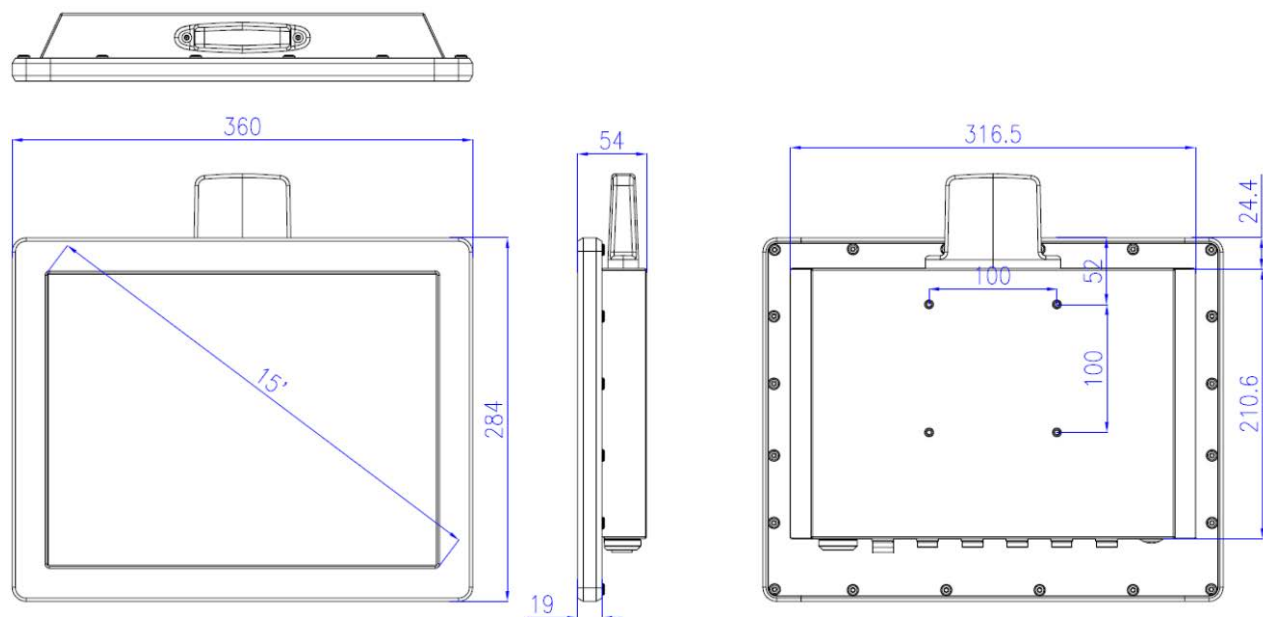

A: POWER E: LAN
 B: DC IN 12-24V F: LAN
 C: RS485/232 G: USB
 D: RS485/232 H: USB