

Model: PCT-3315
15" Fanless Capacitive Touch Panel PC - Intel Celeron J1900; 6 x COM; IP65 front protection



Main Feature

- LED Panel - Higher Brightness; Longer Life Span; Better Viewing Angle; Less Power Consumption ...
- 15" XGA LED Panel support 1024x768 pixels
- Intel Celeron J1900 (2.0GHz, Quad Core)
- 8mm Aluminum Magnesium Alloy front bezel
- NEMA4 / IP 65 compliant front panel, with Rugged construction design
- Front flat glass (7H Hardness) with projected capacitive Multi Touch Screen
- Supports 10 points multi-touch in Windows 7/8.1/10...
- 6 x RS232 serial port
- (Optional - WIFI) MINI PCI-E WIFI Module with Antenna
- Panel (Flush) mounting with clip
- Meet standard VESA hole (100 x 100mm), support desk top stand / wall mount / swing arm mounting

Application

- Factory Automation; Processor Automation; Power Generation; Marine / Offshore Industrial; Kiosk ...

Specification	
Product Model	PCT-3315
Processor	Intel Celeron J1900 (2.0GHz, Quad Core, 2MB Cache, up to 2.41 GHz w/ burst frequency enabled)
Chipset	Intel® SOC integrated
Memory	1 x DDR3L SO-DIMM Socket up to 8GB
Storage	Space for 1x 2.5" HDD/SSD, support mSATA
Display	Display Type : 15" XGA <u>LED Panel</u> LCD Resolution : 1024 x 768 Luminance : 400 cd/m2 View Angel : 160° (H), 160° (V)
LAN	2 x Realtek ® RL8111E (Gigabit) 10/100/1000Ethernet
USB port	1 x USB 3.0 and 3 x USB 2.0
Display output	1 x VGA and 1 x HDMI

Expansive interface	1 x Mini PCI-E (support WIFI & 3G card)
Back panel I/O port	2 x RJ45; 1 x USB 3.0; 3 x USB 2.0; 1 x VGA ; 1 x HDMI; 6 x COM; 1 x Power / Reset Switch; 1 x 12VDC input terminal
Supporting OS	DOS; Windows 7/8.1/10; Linux
Touch Screen	Internal USB interface controller - Projected Capacitive Multi Touch (10 points) Light transmission: 85% or more Surface hardness : 7H Operation system : DOS; Windows XP / 7 / 8.1 / 10; Linux
Wireless LAN (optional)	MINI PCI-E WIFI Module with Antenna
Power Supply	12VDC input terminal
Construction	Heavy duty steel and aluminum front panel
Environment	Operating temperature: -15°C to 60°C Relative humidity: 10% to 90%non-condensing Vibration: 17 to 500HZ 1G PTP; Shock: 1G /peak(11m sec)
Compliance	CE; FCC; ROHS
Dimension W x H x D	371 x 295 x 75 mm
Ordering Information:	
PCT-3315	15" Fanless Capacitive Touch Panel PC - Intel Celeron J1900, with 100-240VAC to DC 12V 60W adapter
<u>Optional - RAM</u>	4 to 8GB DDR3L SO-DIMM RAM
<u>Optional - SSD / HDD</u>	128 GB to 2TB SSD / 500GB to 2TB 2.5'' SATA HDD
<u>Optional - WIFI</u>	MINI PCI-E WIFI Module with Antenna
<u>Optional - OS</u>	Windows 7, 8.1, 10 Professional

Structure Diagram (Panel cut-off dimension: 355 x 279mm)

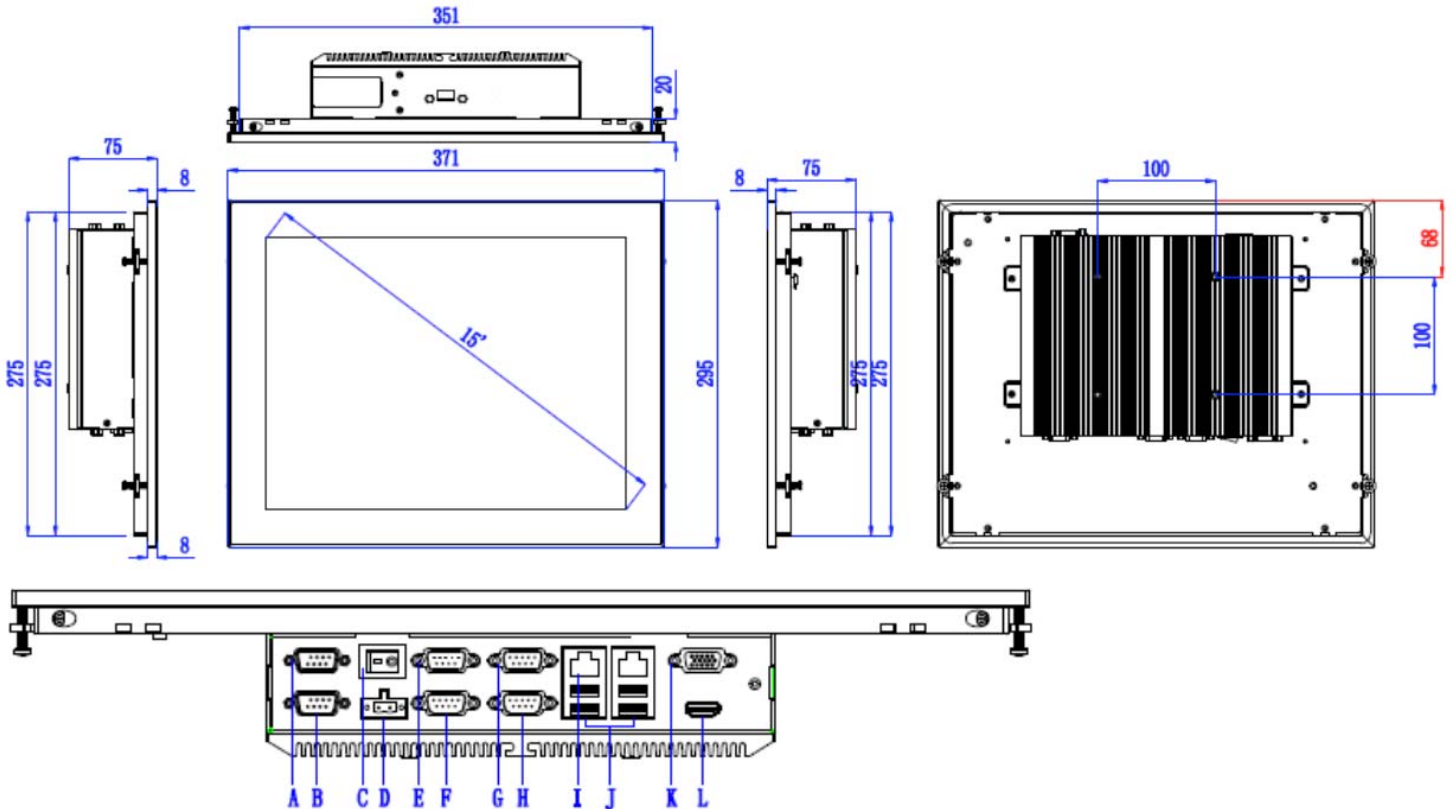

A: COM5 B: COM6 C: PWR On/Off D: PWR In (12VDC) E: COM1 F: COM2 G: COM3 H: COM4
I: GLAN J: USB 2/3.0 K: VGA L: HDMI